

Speake & Co Llanfapley  
6, Firs Road \* Llanfapley \* Abergavenny \* Monmouthshire \* NP7 8SL \* U.K.  
Tel/Fax 01600 780150 \*  
email \* billspeake@btconnect.com

## **FGM-series** **Magnetic Field Sensors**



# Application Notes

## **Magnetometer Integrated Circuit - SCL006B**

This IC makes it possible to construct, very simply, a single axis, sensitive magnetometer for earth field studies.

The design to be described is intended as a robust replacement for the classic, but somewhat delicate "jam-jar" magnetometer, popular with radio amateurs for backup to propagation experiments. For this reason it duplicates the same type of output, namely the small angular fluctuations which occur in the direction of the earth's horizontal field component. In this way it should correlate correctly with other measurements taken by other amateurs in different locations.

The design uses an SCL field sensor type FGM-3. The signal from this is fed into the integrated circuit which performs all the functions required to the level of providing a digital output on eight parallel lines which mirrors the tiny field fluctuations. This output can be fed directly to the input port of a computer for data storage or direct digital display.

For those wishing to use a meter or chart recorder, an additional IC, type AD557, is required to perform a digital to analogue conversion. Nevertheless, the design is simple, using few external components and should be capable of construction by beginners to electronics and those whose interests lie primarily elsewhere.

The sensor is a three terminal device, having two pins for ground and +5 volts respectively and a third pin which gives an output in the form of a rectangular pulse whose period is proportional to the field strength along the device axis. A fourth pin gives access to an internal overwound coil which is ignored in this application, but could be used to vary the zero field frequency of the sensor. The FB terminal on the FGM-3 should be left unconnected.

The IC converts the period variations to an eight bit digital output, but only after considerable amplification and comparison to a chosen zero reference, set by changing the input to one of the IC pins, by switch or by software control from a computer output port. (RESET)

The sensitivity or full-scale range can be coded by programming the levels on two input pins on the IC, either by switches or software control through a computer output port. (S0 and S1). Each increment in this coded input from 00 to 11 increases the sensitivity by a factor of two.

The main circuit is shown overleaf, for use either with a computer or chart recorder, the additional parts required for the meter or chart recorder being shown in a separate diagram. If a computer is used the AD557 can be omitted and the lines D0 (LSB) to D7(MSB) are taken directly to the input port instead. Alternatively for those with a built in analogue converter in their computer, such as the BBC computer has, the AD557 output can be used to input the data via this channel.



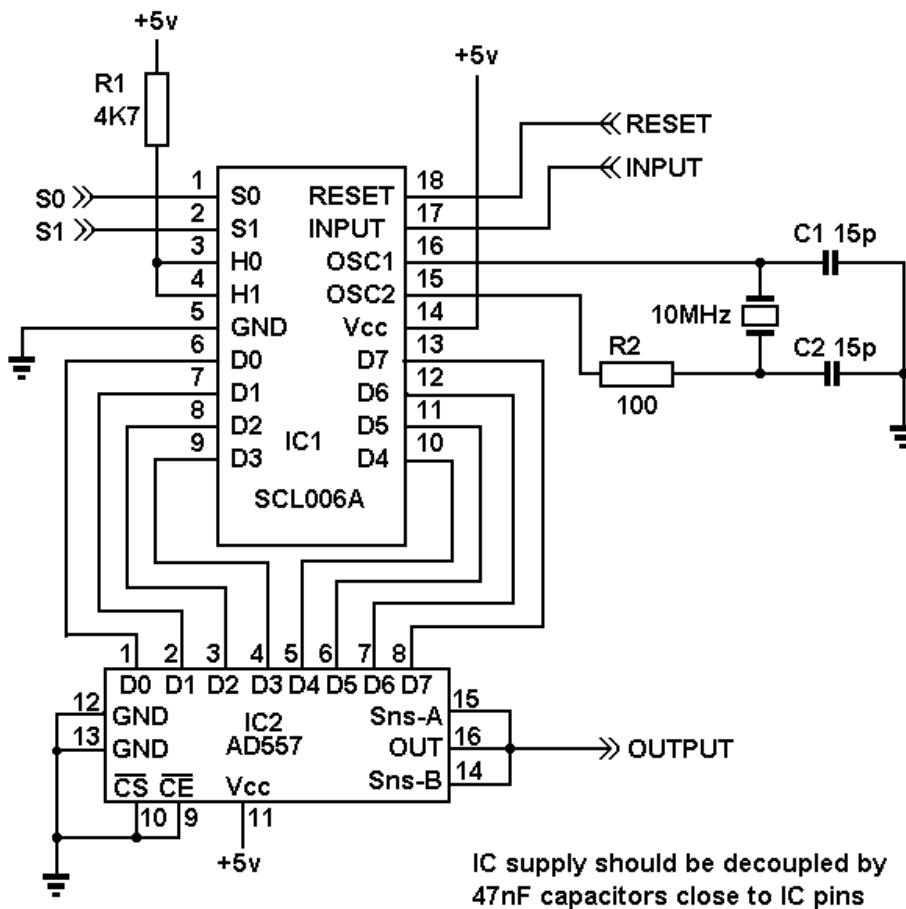

**Main Circuit**

If a meter or chart recorder is used, it should be remembered that the AD557 is capable of providing up to 5 mA at its output for this purpose. Full scale analog output for the AD557 is 2.56 volts.

In the case of a meter or current sensitive chart recorder a series 5K variable resistor will permit adjustment of the scale readings. A meter with a 1 milliampere full scale movement may be used with a 5K potentiometer in series to provide full scale adjustment. The same can be done for a voltage sensitive chart recorder by using a larger variable resistor in potentiometer configuration.

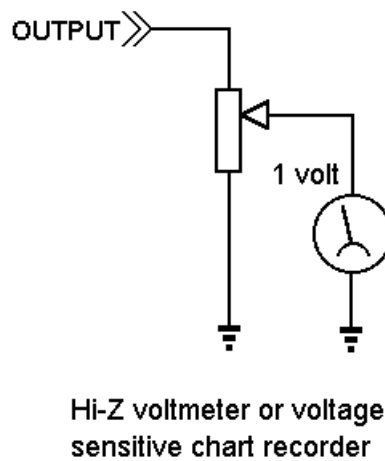
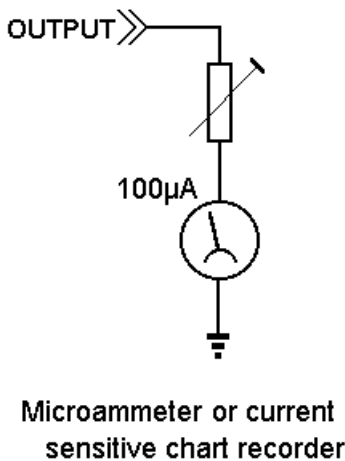

If direct digital input is chosen, it should be noted that there is no strobe, interrupt or handshaking facility available from the chip. This gives rise to the risk of data lines changing during input, causing incorrect reading. The program should take two readings in rapid succession and only accept data if they are identical, taking a third reading if necessary to obtain this identity. This problem does not arise in the case of a computer using an internal analogue to digital converter. The SCL006B output changes once every 8 seconds and the computer input scan rate need only be slightly higher than this to collect all the available data.

If this rate is still too high for some applications, the computer can be used to average the readings over a longer period before storing or displaying the results. Typically, a plotted point once every three or four minutes will produce a 24 hour recording across the screen, depending on the screen resolution in use.

In normal use the sensor will be mounted horizontally with its long axis lying on an east-west line. On power-up the output will automatically move to half-scale and all subsequent field variations will be measured up and down from there. At any later time the output can be set again to the centre-scale position by applying a ground level to the reset pin **for longer than one second**. This can be done by switch or computer control and allows the user to remove any apparent bias in the reading range, caused by switching on by chance on a peak fluctuation.

The following switch arrangements will provide the control signals needed by the chart recorder type systems. The sensitivity switch is shown in the least sensitive position which gives a range of approximately +/- 1000 gamma (NT).

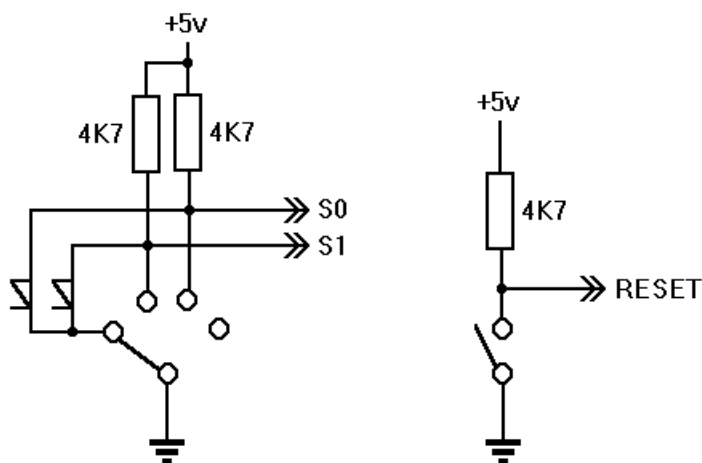

### Manual Sensitivity and Reset Switches

If the user wishes to calibrate the output, it is possible to achieve a reasonably good relative calibration with simple equipment. A single layer close wound coil into which the sensor can be inserted is all that is needed in the way of additional hardware. It can be wound on a cardboard or plastic tube using any wire available from enamelled to plastic covered link-up wire. Ideally the coil should be about ten times as long as its diameter, so it is advantageous to use the smallest diameter tube into which the sensor will slide. The sensor should be placed in the centre during calibration but exact positioning is not critical.

The information needed for calibration is the length of the winding in millimetres and the total number of turns. Multiply the number of turns by 1000 and divide by the length to obtain the number of turns per metre,  $N$ . If a current of  $i$  amperes is passed through this coil the magnetic field at its centre, in units of amperes/metre is just  $N \times i$ . To convert this to oersted  $N \times i$  should be divided by 80. To convert to gamma multiply by 1250.

The field in such a coil will be uniform over the length of the sensor to better than 0.5%. To correct for the finite length of the coil multiply the figure obtained above by 0.992 for best results.

The current required is small. Typical plastic coated wire, for example close winds to about 835 turns /metre and 0.5 mA will produce just over 500 gamma. A simple series 10K potentiometer and milliammeter connected to the 5 volt power supply will suffice.

During calibration the sensor should be set in the east-west position away from potential sources of interfering magnetic field.

The output impedance of the sensor is 330 ohms and the leads to it can be augmented by quite long lengths of cable without much effect on the rectangular pulse output. This permits the sensor to be located remotely from the rest of the equipment, something that is normally necessary to avoid local field anomalies caused by ferrous metal objects being moved around and electronic equipment or electrical cables. Moving vehicles, for example can be detected at distances of 4 to 5 metres. Burying the sensor at the bottom of the garden away from the road is a possible strategy to resolve this. If the sensor is buried or located outdoors, then suitable weather and moisture proofing may be obtained by sealing the sensor inside a length of plastic pipe. Burying the sensor will also minimise temperature fluctuations which if extreme, can drive the output of the SCL-006B off-scale. For this reason, it is recommended that the sensor, even if sealed in a plastic pipe, should not be exposed directly to outdoor temperature variations. This will not harm the sensor, but introduces another variable into the output data, the magnitude of which may rival the actual earth field fluctuations.

Although the sensor has been designed to minimise RF harmonic radiation, it is advisable to use screened (shielded) cable to the sensor and also to decouple the power supply with a 10 to 47 uF tantalum or electrolytic capacitor as close to the sensor as possible to avoid potential harmonic pickup. The sensor connections are shown in the diagram below.

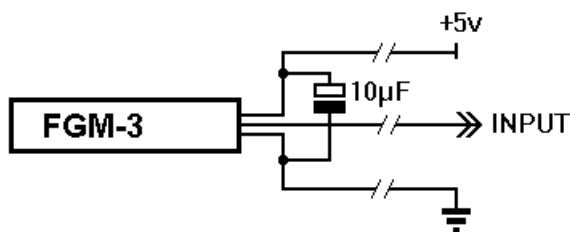

### Sensor Connections